

# BES SERIES

006023  
Issue 2

## Battery Safety Electrolyte Sensor

First Vent Detection | Patented Rate of Change Algorithm | Automotive Grade



### DESCRIPTION

The Battery Safety Electrolyte Sensor (BES) is an automotive-grade sensor designed for early detection of venting and thermal runaway in battery systems. Utilizing an advanced and patented rate of change algorithm, the BES detects battery electrolyte vapor commonly released during the initial venting phase called First Vent, as well as hydrogen and carbon monoxide gases released during a thermal runaway event.

The ability to detect the First Vent provides an essential early warning for potential thermal runaway incidents in Lithium-Ion battery packs. This proactive early detection facilitates timely and appropriate mitigation measures, significantly reducing the risk of thermal runaway. BES employs a patented advanced rate of change algorithm designed to identify significant changes in the concentration of target gases within a sealed battery pack. This innovative method effectively reduces the occurrence of false negatives that may be seen with conventional ppm-based sensors, which focus on precise target gas threshold monitoring. The algorithm is tuned to prevent false positives, improving the end-user experience. Furthermore, the algorithm is supported by more than 12 years of rigorous research and validated through seven years of practical field deployment.

This extensive experience not only enhances the reliability of the detection algorithm but also underscores its effectiveness in real-world applications. BES enhances the safety and reliability of automotive battery systems.

### EARLY DETECTION OF THERMAL RUNAWAY FOR ELECTRIC VEHICLES

#### Sensing

- Battery electrolytes
- Hydrogen
- Carbon monoxide
- Humidity (customizable upon request)
- Pressure (customizable upon request)
- Temperature

#### OUTPUT

BES provides three types of output via CAN message:

- Scalar value indicating volume of gas released by the Li-ion battery cell(s)
- Ambient temperature value
- Alarm flag indicating thermal event

**STOP NOTE:** BES is designed for single use only. It must be replaced after exposure to a thermal event.

#### OPERATING MODES

The sensor functions in the following operating modes selectable via CAN command:

- **ECO Mode:** In ECO mode, CAN communication is disabled which reduces power consumption by 60%. In the event of an alarm condition, the sensor will automatically return to NORMAL mode and send alarm signals to the BMS
- **NORMAL Mode:** In NORMAL mode, the sensor provides full functionality with CAN communication enabled

### APPLICATIONS

Sealed lithium-ion battery packs or modules used in electric, hybrid vehicles and other on-road applications

### FEATURES

- Responsive to battery electrolyte vapor released during the first vent (before thermal runaway)
- Responsive to hydrogen gas released during thermal runaway
- Responsive to carbon monoxide gas released during thermal runaway
- Patented rate of change algorithm to mitigate false negatives
- Resistant to siloxane poisoning
- Compatible with all Lithium-ion battery chemistries and cell types
- Automotive product with CAN 2.0B output with diagnostic features
- Tested for performance life of 15 years

### VALUE TO CUSTOMERS

- **Enhanced asset protection:** Battery electrolyte vapor monitoring provides early warning of thermal events, enabling thermal runaway prevention and asset preservation
- **Reliable battery health monitoring:** BES responds to multiple gases that are typically released during thermal runaway, therefore increasing detection reliability and reduces false negatives
- **Ease of integration:** The rate of change algorithm eliminates the need for precise target gas threshold testing and validation. As a result, it significantly reduces integration costs and timeline

### PORTFOLIO

The BES Series joins the Battery Monitoring Suite. To view the entire product portfolio, [click here](#).

**Honeywell**

# BATTERY SAFETY ELECTROLYTE SENSOR BES SERIES

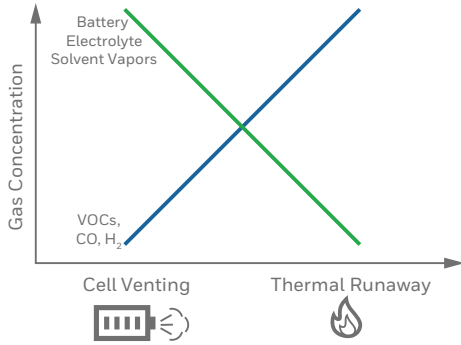

## PRINCIPLE OF OPERATION

During a thermal runaway event, various gases are released. In the early stage, the cell vents a high concentration of electrolyte vapor. This includes gases such as Ethylene carbonate (EC), Diethyl carbonate (DEC), Ethyl Methyl carbonate (EMC) and Dimethyl carbonate (DMC) etc.

As the event progresses to an explosion, there is an increase in H<sub>2</sub> and CO.

The BES Series sensor is equipped with a siloxane-resistant metal oxide semiconductor sensor that is highly sensitive towards electrolyte vapors, H<sub>2</sub> and CO. Due to its sensitivity to multiple target gases, the BES sensor ensures reliable and early detection compared to traditional gas sensors.

The BES sensor is equipped with a patented built-in rate of change algorithm, which triggers an alarm upon the detection of any of the target gases. This feature ensures quick and precise response to gas presence, enhancing safety and monitoring efficiency.

PPM based gas sensors may drift over a period increasing the risk of missing critical warning of thermal events. The BES rate of change algorithm approach addresses this concern as precise ppm monitoring is not required, ensuring early and reliable alerts.

## Test A: Early detection of thermal runaway with the Honeywell BES sensor rate of change algorithm compared to other ppm-based gas sensors

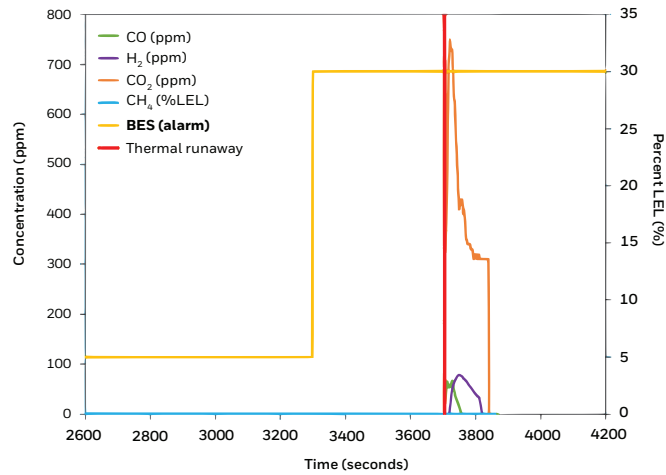

- In this test a pouch cell is overcharged at 2C rate to induce thermal runaway or explosion
- BES sensor alarms ~7 minutes before thermal runaway
- H<sub>2</sub>, CO, CO<sub>2</sub> and CH<sub>4</sub> gas sensors showed ppm response only during the cell explosion/thermal runaway

## Test B: BES sensor enabling prevention of thermal runaway by removing abuse factor

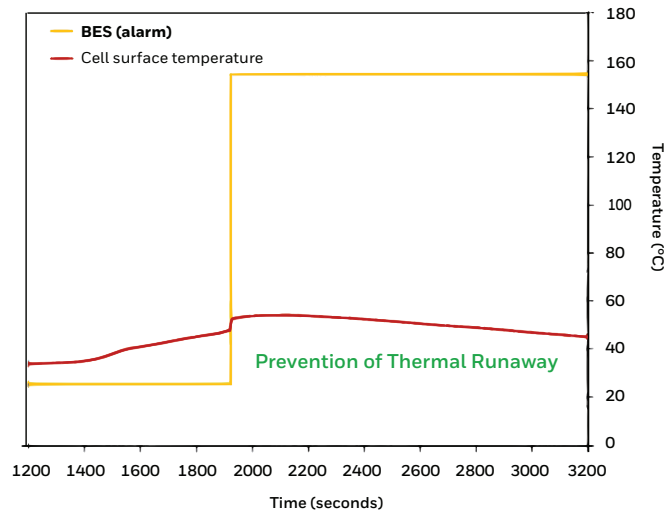

- In this test a pouch cell is abused by overcharging at 2C rate. Once the BES alarm is triggered, the charging is turned off
- Cell cools down and thermal runaway is prevented
- BES detected thermal runaway early enough to enable the prevention of thermal runaway by removing the source of abuse

# BATTERY SAFETY ELECTROLYTE SENSOR BES SERIES

**TABLE 1. KEY SPECIFICATIONS**

Characteristic	Parameter	
<b>Performance</b>		
Gas sensed	Electrolytes vapors <sup>1</sup> , H <sub>2</sub> , CO	
Temperature measurement	-40°C to 125°C	
Pressure measurement <sup>2</sup>	60 kPa to 165 kPa	
Response time	<5 seconds	
Startup time	<2 seconds	
Algorithm initialization time	<75 seconds	
Severity of gas detected	-2.00 = typical warm-up condition 0.00 = clean air 1.00 = alarm trigger >4.00 = typical high level of gas	
Vibration	5.9 Grms, 10 Hz to 2000 Hz	
Safety rating	QM grade	
MTTF/MTBF	1.3 million hours / 150.86 years	
Location of sensor	Sensor can be installed anywhere in battery pack, provided sensing port is unobstructed	
<b>Electrical</b>		
Supply voltage	Nominal: 12 Vdc, Range: 8 Vdc to 16 Vdc	
Over voltage	Maximum of 26 V for 60 s	
Reverse voltage	Maximum of 20 V	
Current consumption	1. In ECO mode, 9 mA typical 2. In NORMAL mode, 20 mA typical	
<b>Environmental</b>		
Operating temperature	-40°C to 85°C	
Storage temperature	-40°C to 85°C	
Humidity	0 to 90 %RH	
Siloxane poisoning	15 years of life in 570 ppb siloxane exposure	
ROHS, Reach	Yes	
<b>CAN Bus</b>		
Protocol	SAE J1939 CAN 2.0B	
Baud rate	250/500 Kbps	
Short circuit protection	Yes	
Broadcast rate	1 second	
<b>CAN Bus Parameters</b>	<b>Minimum</b>	<b>Maximum</b>
CAN H/L voltage range (V)	-45	45
Dominant differential output (V)	1.5	3
Recessive differential output (V)	-0.12	0.012
<b>Mechanical</b>		
Connector	USCAR 120-S-004-1-Z02 (Keying Option A) Mating Connector: Molex <sup>®</sup> 349004120	
Mounting	M5 GRADE 8.8 BOLT (X2), recommended mounting torque is 6 Nm ±1 Nm	
Weight	40 g max.	
Dimensions	78,88 mm × 64,13 mm × 17,00 mm	
Housing Material	VALOX DR48 17 % GF	
Flammability	UL 94 V-0	
Ingress Protection	IP3X	

1. EC, PC, DEC, DMC and other electrolytes used in lithium-ion cell

2. Not in standard offering. Available upon demand

# BATTERY SAFETY ELECTROLYTE SENSOR BES SERIES

Figure 1. Product Dimensions

TABLE 2. PIN OUT

Pin	Description
1	Power input
2	Ground
3	CAN H
4	CAN L

**NOTE:** BES is designed for single use only. It must be replaced after exposure to a thermal event.

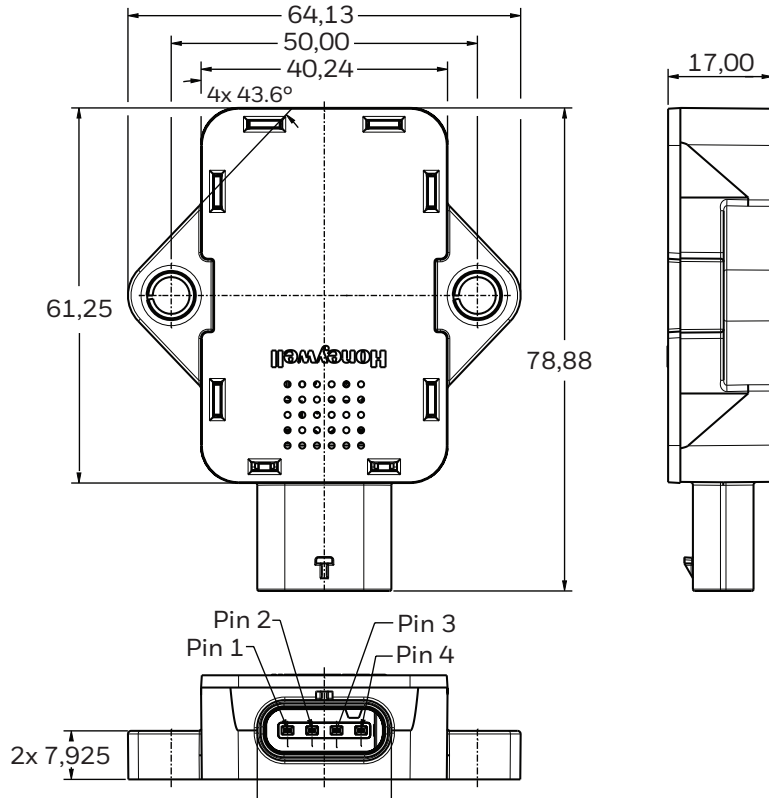
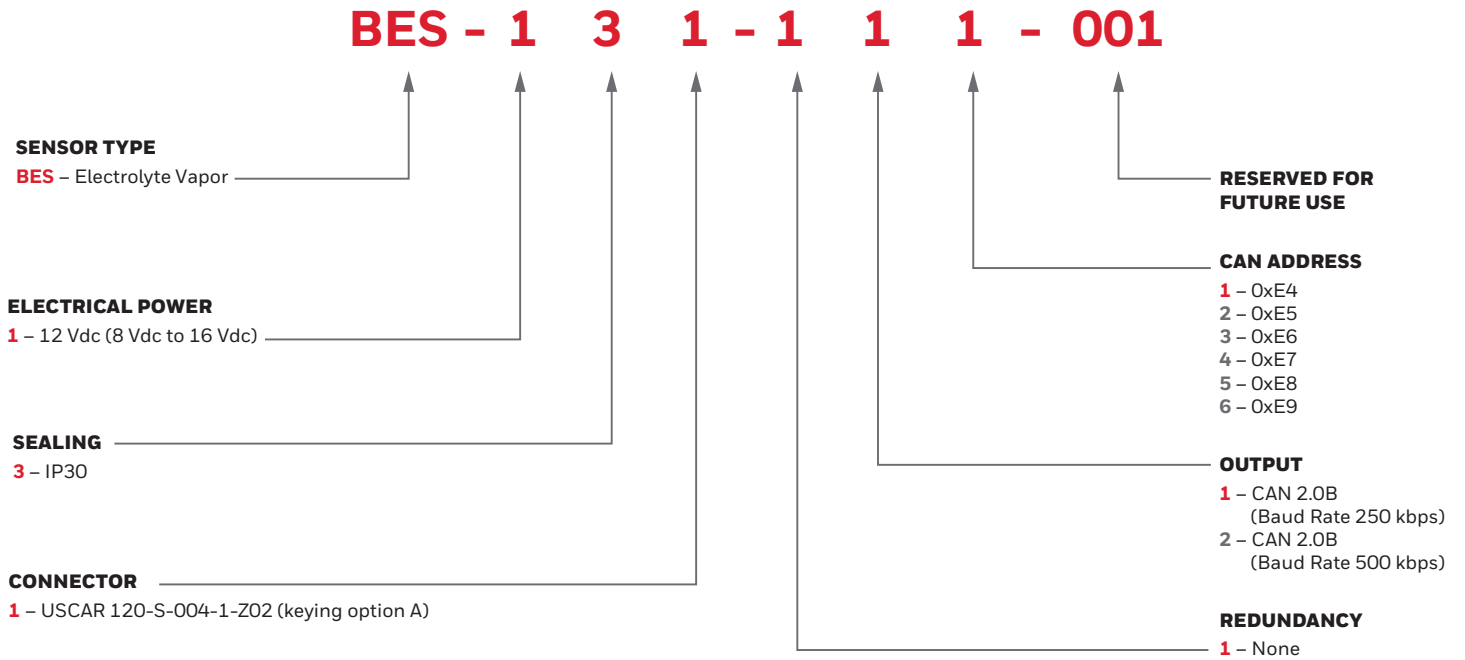

Figure 2. Product Nomenclature



# BATTERY SAFETY ELECTROLYTE SENSOR BES SERIES

## SENSOR STATE FORMAT | PDU 0XFF01/65281

Frame Format	29-BIT ID						DATA (8 BYTES)							
Field	P	EDP	DP	PF	PS	SA	State	Deg C	Scalar		Not Used			
									Low Byte	High Byte				
# Bits	3	1	1	8	8	8	8	8	8	8	8	8	8	8
CAN Message	0x08			0xFF	0x01	0xE4	0x03	0x17	0x1C	0x00	0xFF	0xFF	0xFF	0xFF

### 29 BIT ID

Message	Description
EDP/DP=0	J1939 standard data page
PF = 0xEF	Peer-to-peer message
PS = 0x01	Destination address (address of the controller)
SA = 0xE4	Source address (address of BES sensor)

### STATE: REPRESENTS THE STATE OF SENSOR

Message	Description
Error	0x01
Warmup	0x02
Normal	0x03
Alarm	0x04

### Deg C

Temperature (C) = (int8\_t) \* Deg C

Value=(int16\_t) Scalar/100

Typical warm up	-2.00
Clean Air	0.00
Thermal runaway alarm	>1.00
High level of electrolytes	>4.00

Example

Broadcast Normal Operation at 23°C (0x17h=23) and 0.28 Scalar (0x001C = 28)

## SENSOR OPERATING MODE | PDU 0xEF00/61184

Frame Format	29-BIT ID						DATA (2 BYTES)	
Field	P	EDP	DP	PF	PS	SA	ID	CMD
# Bits	3	1	1	8	8	8	8	8
CAN Message	0x19			0xEF	0xE4	0xF6	0x01	0x00

### ID

ID for operating mode is 0x01

**CMD: Determines operating mode**

NORMAL Mode	0x01
ECO Mode	0x02
No Change	0x00

## SENSOR DIAGNOSTIC OUTPUT | PDU 0xFECA/65226

Frame Format	29-BIT ID						DATA (8 BYTES)							
Field	P	EDP	DP	PF	PS	SA	Light	Flash	DTC		Occ	NA	NA	
# Bits	3	1	1	8	8	8	8	8	8	8	8	8	8	
CAN Message	0x18			0xFE	0xCA	0xE4	0x04	0x0C	0x71	0xE2	0xFF	0x03	0xFF	0xFF

This message is broadcasted every 1 second while DTC is active

### Diagnostic Messages

Severity	Protect=0, Warning=1, Stop=2, Malfunction=3
Light	0=Off, 1=On, 2=Error, 3=Any
Flash	0=slow, 1=fast, 3=no flash
DTC	0x7E000 - 0x7FFFF refer to fault codes
FMI	most severe=0, 0x1F = not available: ref J1939-73
Occurrence	1-127

Example

BES Sensor CRC Error (Light=1, Flash = 3, Severity = 1, DTC=0x7E271, FMI = 0x1F, occurrence = 3)

### Example

ID	18FECAE4x
Data	04 0C 71 E2 FF 03 FF FF

# BATTERY SAFETY ELECTROLYTE SENSOR BES SERIES

The DM3 message is used to clear stored and active DTCs.

## DM3 (J1939-73 Standard) | PDU 0xFECC / 65228

Frame Format	29-BIT ID						DATA (8 BYTES)							
Field	P	EDP	DP	PF	PS	SA								
# Bits	3	1	1	8	8	8	8	8	8	8	8	8	8	8
CAN Message	0x18			0xFE	0xD3	0xE4	0xFF	0xFF	0xFF	0xFF	0xFF	0xFF	0xFF	0xFF

## DTC FAULT CODES

DTC	Severity	Light	Flash	Description
0x7E100	Stop Now	ON	No	App firmware missing
0x7E101	Replace	ON	FAST	App CRC check failed
0x7E110	Stop Now	ON	No	Config file missing
0x7E111	Replace	ON	FAST	Config CRC check failed
0x7E120	Replace	ON	No	Build file missing
0x7E121	Replace	ON	FAST	Build CRC check failed
0x7E242	Warning	OFF	No	Watchdog
0x7E250	Warning	OFF	No	Temperature too hot (greater than 85°C)
0x7E251	Warning	OFF	No	Temperature too cold (less than -40°C)
0x7E270	Warning	OFF	No	Gas sensor error
0x7E271	Warning	OFF	No	Gas sensor CRC
0x7E272	Warning	OFF	No	Gas sensor out of range
0x7E280	Warning	OFF	No	Event duration too long (alarm greater than 1 hour)

# BATTERY SAFETY ELECTROLYTE SENSOR BES SERIES

**TABLE 3. EMC TEST SPECIFICATIONS**

Test	Standard	Procedure
CISPR 25 Conducted RF Emissions - Voltage	CISPR25	Section 6.2, Class 3
CISPR 25 Conducted RF Emissions -Current	CISPR25	Section 6.3, Class 3
CISPR 25 Radiated Emissions	CISPR25	Section 6.4, Class 3
Transient Conducted Emission	ISO 7637-2	Section 6.2
Bulk Current Injection (BCI) Test	ISO 11452-4	Frequency range: 1 MHz to 400 MHz, Test Level 200 mA
RF Radiated Immunity - ALSE	ISO 11452-2	Frequency range: 200 MHz to 1 GHz, Test Level 150 V/m 1 GHz to 6 GHz, Test Level 100 V/m
RF Radiated Immunity - Stripline	ISO 11452-5	Frequency range: 10 kHz to 400 MHz, Test Level: 200 V/m
Electrostatic Discharge	ISO 10605	Unpowered direct contact discharge: ±6 kV Unpowered air discharge: ±15 kV Powered-up direct contact discharge: ±8 kV Powered-up air discharge: ±15 kV Network: 330 pF / 330 Ω

**TABLE 4. ELECTRICAL TEST SPECIFICATIONS**

Test	Standard	Procedure
Long Duration Overvoltage	ISO 16750-2	Section 4.3.1.2 - Jumpstart
Transient Overvoltage	ISO 16750-2	Section 4.3.2
Superimposed Alternating Voltage	ISO 16750-2	Section 4.4, Levels 3 and 4
Slow Decrease / Increase of Supply Voltage	ISO 16750-2	Section 4.5
Momentary Drop in Supply Voltage	ISO 16750-2	Section 4.6.1
Reset Behavior at Voltage Drop	ISO 16750-2	Section 4.6.2
Reverse Voltage	ISO 16750-2	Section 4.7, Test case 2
Open Circuit	ISO 16750-2	Section 4.9
Short Circuit Protection	ISO 16750-2	Section 4.10.2
Insulation Resistance	ISO 16750-2	Section 4.11 ,10 MΩ at 500 Vdc

**TABLE 5. ENVIRONMENTAL TEST SPECIFICATIONS**

Test	Standard	Procedure
Low Temperature Operating	ISO 16750-4	Section 5.1.1, T <sub>MIN</sub> : -40°C
High Temperature Operating	ISO 16750-4	Section 5.1.2, T <sub>MAX</sub> : 85°C
Thermal Step	ISO 16750-4	Section 5.2, Temp Range: -40 to 85°C
Thermal Cycle	ISO 16750-4	Section 5.3, Temp Range: -40 to 85°C
Humid Heat, Cyclic	ISO 16750-4	Section 5.6, Test 1 and 3
Damp Heat, Steady-State	ISO 16750-4	Section 5.7
Atmospheric Pressure	ISO 16750-4	Section 5.12, -100 m to 5000 m
Random Vibration	ISO 16750-3	Section 4.1 Test VII, Commercial Vehicles
Mechanical Shock	ISO 16750-3	Section 4.2, Shock Profile II
Handling Drop	ISO 16750-3	Section 4.3, 1 m drop
Withstand Voltage	ISO 16750-2	Section 4.12, 500 Vrms, 60 Hz for 60 s

## WARRANTY/REMEDY

Honeywell warrants goods of its manufacture as being free of defective materials and faulty workmanship during the applicable warranty period. Honeywell's standard product warranty applies unless agreed to otherwise by Honeywell in writing; please refer to your order acknowledgment or consult your local sales office for specific warranty details. If warranted goods are returned to Honeywell during the period of coverage, Honeywell will repair or replace, at its option, without charge those items that Honeywell, in its sole discretion, finds defective. **The foregoing is buyer's sole remedy and is in lieu of all other warranties, expressed or implied, including those of merchantability and fitness for a particular purpose. In no event shall Honeywell be liable for consequential, special, or indirect damages.**

While Honeywell may provide information or engineering support for its products through Honeywell personnel, literature and website, it is the buyer's sole responsibility to determine the suitability of the Honeywell product(s) for the buyer's requirements.

Specifications may change without notice. The information we supply is believed to be accurate as of this writing. However, Honeywell assumes no responsibility for its use.

### For more information

Honeywell Sensing Solutions services its customers through a worldwide network of sales offices and distributors. For application assistance, current specifications, pricing, or the nearest Authorized Distributor, visit [automation.honeywell.com](https://automation.honeywell.com) or call:

USA/Canada	+302 613 4491
Latin America	+1 305 805 8188
Europe	+44 1344 238258
Japan	+81 (0) 3-6730-7152
Singapore	+65 6355 2828
Greater China	+86 4006396841

### Honeywell Sensing Solutions

830 East Arapaho Road  
Richardson, TX 75081  
[www.honeywell.com](https://www.honeywell.com)

## WARNING PERSONAL INJURY

DO NOT USE these products as safety or emergency stop devices or in any other application where failure of the product could result in personal injury.

**Failure to comply with these instructions could result in death or serious injury.**

## WARNING MISUSE OF DOCUMENTATION

- The information presented in this product sheet is for reference only. Do not use this document as a product installation guide.
- Complete installation, operation, and maintenance information is provided in the instructions supplied with each product.

**Failure to comply with these instructions could result in death or serious injury.**